

METEOR TS630V

METEOR TS630V

flexible twin spindle machine with adjustable spindle distance

The machining center METEOR TS630V is made for the highest requirement of high performance production lines and is available in 4- or 5-axis. The adjustable spindle distance offers the maximum flexibility. For customers looking for short cycle times and loading/unloading times, the machine can be optionally equipped with a pallet changer.

YOUR ADVANTAGES

- Specially developed for aluminum processing
- Maximum flexibility thanks to 2 independent spindles
- Automatic pallet changer increases your productivity
- Small installation area reduces the floor space required
- Efficient drives reduce your energy cost

TYPICAL PARTS

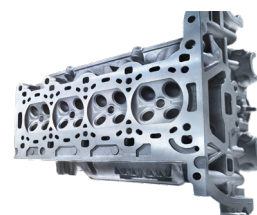

Tool changer
Automatic disc tool changer

Magazine capacity: 2 x 34 (optional 2x40/52)
Chip-to-chip time: 3.3 s

Automatic pallet changer
(optional)

Change time 8 s chip-to-chip

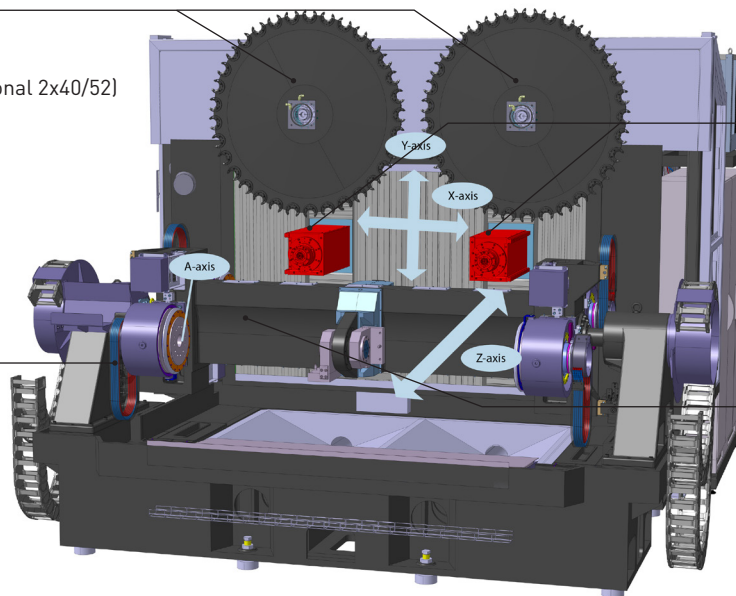

Spindle
2 x 30kW spindle
HSK63-A
up to 18000 rpm

Max. tool- ϕ : 230mm
Max. tool length: 320mm

Pallet
630-1300 x 630mm
part max. ϕ 800 x 2175mm

		METEOR TS630V	METEOR TS630V-P	
number of axes	number of axes*	4	4	
spindles	number of spindles	2	2	piece
	spindle distance	545-1805	545-1805	mm
working range	X-axis	630-1300	630-1300	mm
	Y-axis	630	630	mm
	Z-axis	630	630	mm
max. part size	X/Y/Z	ϕ 800 x 2175	ϕ 800 x 2175	mm
feed rate	acceleration [X/Y/Z]	8/15/20	8/15/20	m/s ²
	max. speed [X/Y/Z]	90/80/80	90/80/80	m/min
accuracy	positioning accuracy acc. VDI 3441/2617	0.006	0.006	mm
	repeatability acc. VDI 3441/2617	0.002	0.002	mm
spindle	speed	0-18000	0-18000	rpm
	power [S1/S6]	30/50	30/50	kW
	torque [S1/S6]	45/80	45/80	Nm
tool magazine	tool holder	HSK63-A	HSK63-A	
	tool capacity*	2 x 34	2 x 34	piece
	max. tool diameter	230	230	mm
	tool length*	320	320	mm
	tool weight	8 /16	8 /16	kg
	chip-to-chip time at 1800 rpm	3.3	3.3	s
parts and clamping dimension	rotations diameter	800	800	mm
	length	2175	2175	mm
	max. load on A/B	2 x 500/250	2 x 500/250	kg
	automatic pallet changer - change time (chip-to-chip)	-	8	s
weight/dimensions	weight	11670	20015	kg
	dimension LxWxH	4195 x 2390 x 3419	5480 x 2950 x 3419	mm
connected load	operating voltage	3x 400	3x 400	Volt
	total connected load	55	55	kVA
NC control	Siemens*	Sinumerik 840 D SL	Sinumerik 840 D SL	
* options available				
options	number of axes	5	5	
	tool capacity	2 x 40/52	2 x 40/52	piece
	tool length	510	510	mm
	Fanuc control	31i-MB	31i-MB	